

# INSTRUCTIONS FOR USE

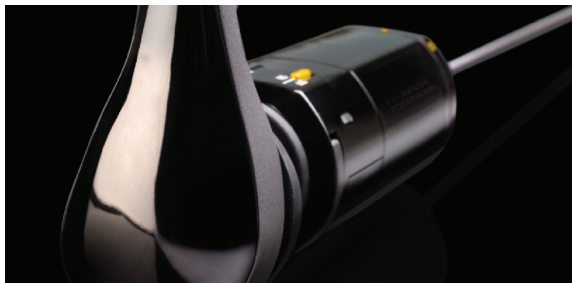

**POWERED LAPAROSCOPIC DEVICE**



4 Meir Ariel St., Grand Netter Building  
Netanya 4250574, Israel  
Telephone +(972)-77-3630300

EC	REP
----	-----

Obelis S.A Registered Address: Bd. Général Wahis, 53 1030  
Brussels, Belgium



## COMPONENTS OF THE HANDX



COMPONENT	DESCRIPTION
<b>HandX</b> Contains: <ul style="list-style-type: none"><li>• HandX case</li><li>• HandX</li><li>• Power adapter</li></ul>	Capital equipment 2 Handpieces 2 Adapters
<b>HandX Disposables</b> Contains: <ul style="list-style-type: none"><li>• HandX Arc &amp; Finger Pads</li><li>• HandX DC Power Cable</li></ul>	Disposable, Sterile, Single Use 1 Arc with 1 Spacer, 2 Finger Pads Cable Length- 3.5m
HandX instrument- Needle Holder	5 mm/Disposable Single Use
HandX instrument- Fenestrated Grasper	5 mm/Disposable Single Use

## STANDARD CONVENTIONS USED



The Use of CAUTION, WARNING, and NOTE Statements.

Information relative to the completion of a task in a safe and thorough manner will be supplied in the form of a Caution, a Warning, or a Note statement. These statements are found throughout the documentation.

These statements should be read before continuing to the next step in a procedure.

**WARNING:** A Warning statement indicates an operating or maintenance procedure, practice, or condition that, if not strictly observed, could result in personal injury or loss of life.

**CAUTION:** A Caution statement indicates an operating or maintenance procedure, practice, or condition that, if not strictly observed, could result in damage to or destruction of the equipment.

**NOTE:** A Note statement indicates an operating or maintenance problem, practice, or condition that is necessary to accomplish a task efficiently.

## HandX DEVICE DESCRIPTION



The Human Xtensions HandX is a handheld powered laparoscopic device.

The HandX is electromechanically controlled, includes hardware and software and comprises two major parts, the Handpiece and the instrument (Figure 1).

Figure 1: Main HandX Components

### INSTRUMENT

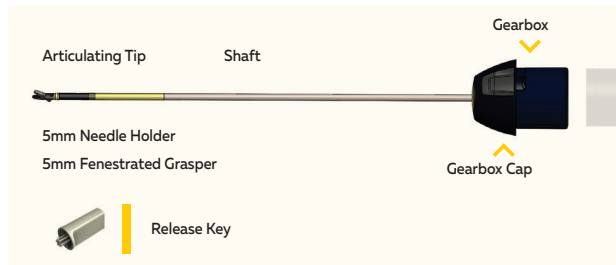

### HANDPIECE

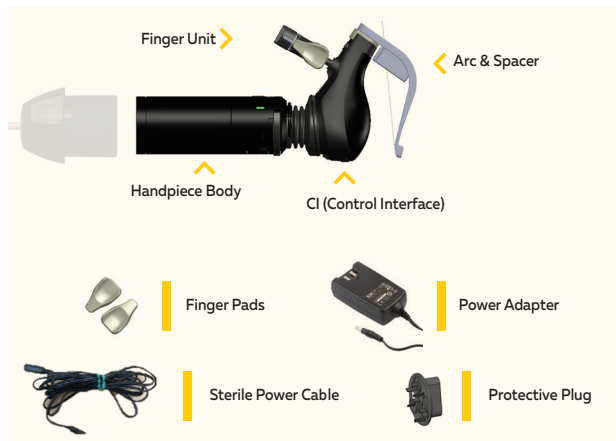

Main HandX Components as Illustrated in Figure 1:

**INSTRUMENT:** Articulating Tip | Shaft | Gearbox Cap | Protective Plug | Gearbox | Release Key.

**HANDPIECE:** Handpiece Body | CI (Control Interface) | Finger Unit Arc, Finger Pads & Spacer | Power Adapter | DC Power cable.

**NOTE:** The HandX is compliant with IEC 60601-1-1 and IEC 60601-1-2

## INDICATION

The Human Xtensions HandX™ device is indicated for surgical treatment of tissue and organ inflammation, benign and/or malignant space occupying lesions, and anatomic deformations in the abdominal, thoracic, and pelvic cavities.

## INTENDED USE

The Human Xtensions HandX™ device is intended to facilitate repair and/or removal of organs and soft tissues during laparoscopic procedures through tissue manipulation and mobilization, ie, stitching and grasping using the Human Xtensions HandX™ device.

## CONTRAINDICATIONS

Where laparoscopic surgery is contraindicated.

## WARNINGS

1. The disposable components of the device are provided STERILE and are intended for use in a single procedure only. DISCARD AFTER USE DO NOT RESTERILIZE. Reuse reprocessing, or re-sterilization may compromise the structural integrity of the device and/or lead to device failure that in return may result in patient injury, illness or death.
2. Endoscopic procedures should be performed only by physicians having adequate training and familiarity with endoscopic techniques. A thorough understanding of the operating principles, risk versus benefits, and the hazards involved in an endoscopic approach is necessary to avoid possible injury to the user and/or patient.
3. Do not use a HandX Handpiece, instruments or HandX Disposables if the device is damaged or the package is damaged or opened or has been dropped, as it could compromise the functionality and/or safety of the products.
4. Do not use past the expiry date.
5. Used HandX instrument and HandX Disposables should be disposed according to bio-hazard disposal practices in accordance with the facility disposal procedure.
6. HandX Handpiece must not be disposed as unsorted waste. Handpiece must be collected separately. Please contact your dealer or supplier for further information.
7. Verify mechanical and electrical compatibility of devices from different manufacturers prior to using them together with the HandX.
8. Do not connect wet instruments or HandX Disposables to the HandX Handpiece.
9. HandX Handpiece should be stored in a cool and dry place between uses.
10. No modification of this device is allowed without authorization of the manufacturer.
11. HandX recovery time after defibrillation is 1 second.
12. The HandX Handpiece shall maintain control of the articulation tip movement at all times. In case of an irregular articulation tip movement, stop using the device.
13. The HandX Handpiece shall only be used with the products provided by Human Xtensions.
14. Portable RF communications equipment should be used no closer than 30 cm (12 inches) to any part of the HandX, including cables specified by the manufacturer. Otherwise, degradation of performance of this equipment could result.
15. Do not disconnect the instrument during operation. In case of inadvertent instrument disconnection, replace the instrument.

**NOTE:** Defibrillation was tested and in compliance with IEC 60601-1.

## USING THE DEVICE



### PRE-OPERATIVE ASSEMBLY

1. Prior to use, remove the Release Key and the instrument from the blister and place it in the sterile field.
2. Remove the Protective Plug from the instrument.

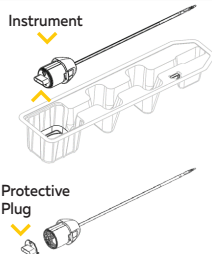

- ⚠ **WARNING:** The non-sterile Handpiece Body and the CI must be covered. The HandX should be used with a standard sterile drape.
- NOTE:** The HandX Handpiece is compatible with standard, Off-the-shelf, sterile drape with inner ring diameter of at least 85 mm (referred to as sterile drape from hereon).

3. **SCRUB PERSON:** After aseptically removing the sterile drape from its packaging, hold the open side of the sterile drape so its opening is facing the tip of the instrument. Carefully slide the instrument into the sterile drape opening.

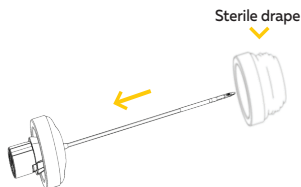

4. Secure the distal end of the sterile drape around the instrument's shaft using standard sterile OR tape, or the sterile tape provided with the sterile drape.



5. **CIRCULATING PERSON:** Identify the flat surface of the instrument Gearbox and the flat surface of the Handpiece.



6. **CIRCULATING PERSON:** Insert the instrument Gearbox into the Handpiece Body distal end, aligning the flat surface of both.

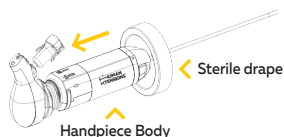

## PRE-OPERATIVE ASSEMBLY

7. **CIRCULATING PERSON:** While connecting the instrument's Gearbox into the Handpiece Body, insert the Gearbox cCap into the Handpiece Body, and rotate the Gearbox Cap counterclockwise until securely locked in place.

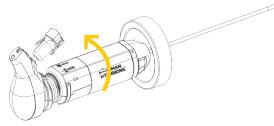

8. **CIRCULATING PERSON:** Roll the sterile drape over the Handpiece Body and the CI, (Maintaining aseptic transfer techniques, as if draping a camera).

**SCRUB PERSON:** Secure the proximal end of the drape using standard sterile operating room tape or the tape provided with the sterile drape, leaving 15-20 cm length of the sterile drape at the top of the CI.

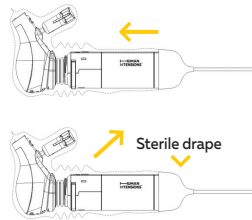

## HANDX DISPOSABLES (ARC & FINGER PADS) ASSEMBLY

9. **SCRUB PERSON:** Pull the sterile drape proximally, until all the slack is over the CI.

10. **SCRUB PERSON:** Slide the Finger Pads over the Finger Pads mounts and Arc over the Finger Pads mounts and Arc over the sterile drape on to the CI, according to the figure.

**NOTE:** The Finger Pads need to be pushed up to bumpers located on the Finger Pads mounts.

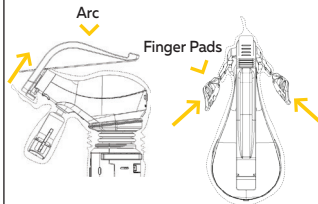

11. **SCRUB PERSON:** Slide the Arc Spacer onto the silicone strap. Install the spacer into its position.

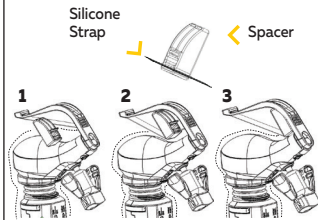

## PRE-OPERATIVE ASSEMBLY

12. **SCRUB PERSON:** Apply tension to the sterile drape towards the CI, connect the distal, male connector of the DC Power Cable to the Handpiece power jack, pushing it through the sterile drape, while maintaining tension.

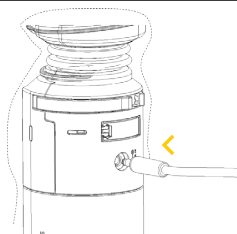

13. **CIRCULATING PERSON:** Connect the proximal, female connector of DC Power Cable to the Power Adapter and plug the Power Adapter into the wall socket.

## USING THE DEVICE (SEE DEVICE STATUS INDICATION TABLE)

14. Ensure that the power switch is in the Status indicator "ON" position. Verify that the status indicator is flashing green.



15. Slide your hand between the CI hand contact surface and the Arc's silicone strap. Tighten the strap by pulling the loose end of the silicon strap if needed for the surgeon's comfort. Adjust the Finger Unit position using the pan & tilt feature.

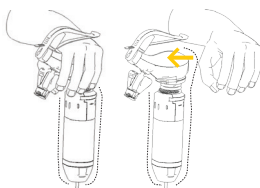

16. Double click the DIALOG Button to activate the device's Operating Mode.

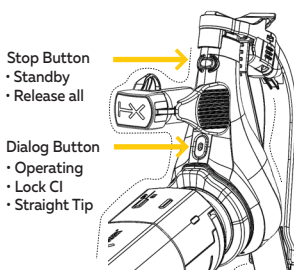



17. PRE-CHECK WHILE DEVICE IS IN FREE MOTION (as described in section 21b) – VERIFY DEVICE OPERATION FOLLOWING THE INSTRUCTIONS BELOW, VERIFY THAT THE TIP MOVES PROPERLY.

a. CLOSE / OPEN– pressing and releasing the Finger Pads 3 times using your fingers.

b. ROLL – Twist the Finger Pads in both directions using your fingers.

c. ARTICULATION – Articulate the whole CI unit “Up”, “Down”, “Left” “Right”.

18. Before inserting the device into the trocar, long press and hold the DIALOG Button (3 seconds) to straighten the tip.



19. Once inserted through the trocar, and under laparoscopic view, double click the “DIALOG” button in order to activate the Operating Mode and unlock the CI. The device is now ready for use.

20. If needed during usage, 1 second press on the “DIALOG” button will lock the CI unit. To unlock the CI, double click the “DIALOG” button.

## 21. ADDITIONAL FEATURES



a. Roll range switch enables graded restriction of rotation of the articulating tip of the instrument.

Roll Range Switch

-  ± 90° (left position)
-  ± 180° (middle position)
-  ± 270° (right position)

b. Planar switch allows conversion between full range of articulation and articulation limited to the yaw axis.

Free or Planar Switch

-  Free motion – Full range articulation (right position)
-  Planar motion – Articulation in the yaw position

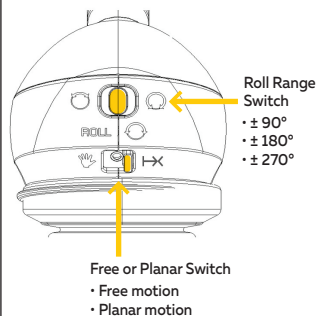

## HANDX REMOVAL PROCEDURE

22. Long press and hold the DIALOG Button (3 seconds) to straighten the tip.

23. Close the Finger Pads to reach a closed grasping position under laparoscopic control.

24. Gently retract the instrument from within the trocar.

- ⚠ **CAUTION:** Do not attempt to insert or remove the instrument from the trocar in the articulated position. The tip of the instrument must be straight, parallel to the shaft. Failure to straighten the instrument will result in difficult insertion or withdrawal and may result in damage to the instrument.

25. WHEN PROMPT RELEASE IS REQUIRED FOLLOW THE SUBSEQUENT STEPS:

- a. **Loose Tip Function** - Press and hold the "STOP" Button (3 seconds) until the Articulating Tip is loosened, the jaws will open and then close, repeat the step if necessary, until the instrument is safe to be removed.

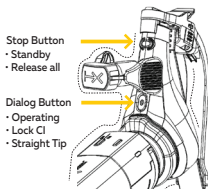

- b. **Release Key (manual)** - If "Loose Tip Function" fails, use the "Release Key" (provided in the blister together with the instrument, or in the HandX Disposables set) to loosen the Tip manually.
- Release the Gearbox from the Handpiece Body by rotating it clockwise.
  - Sequentially insert the Release Key into the sockets located at the proximal end of the Gearbox rotating it fully counterclockwise starting with the middle socket (releasing the jaws and continuing with the rest of the sockets (loosening the articulation). Rotate clockwise the middle socket to close the jaws.

- ⚠ **CAUTION:** Do not attempt to insert or remove the instrument through the trocar in the articulated position or if the jaws are open. The tip of the instrument must be straight, parallel to the shaft. Failure to straighten the instrument will result in difficult insertion or withdrawal and may result in damage to the instrument. The instrument cannot be used any longer if the above functions have been utilized.

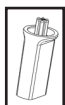

← Release Key



DEVICE DISASSEMBLY

**CIRCULATING PERSON:** Disassemble the Finger Pads and the Arc, carefully roll off and remove the sterile drape from the CI, down to the instrument, detach and dispose according to operating room routine procedure, clean and disinfect the Handpiece according to the "Reprocessing Instructions" section.

Store in cool dry place.

## DEVICE STATUS INDICATIONS TABLE

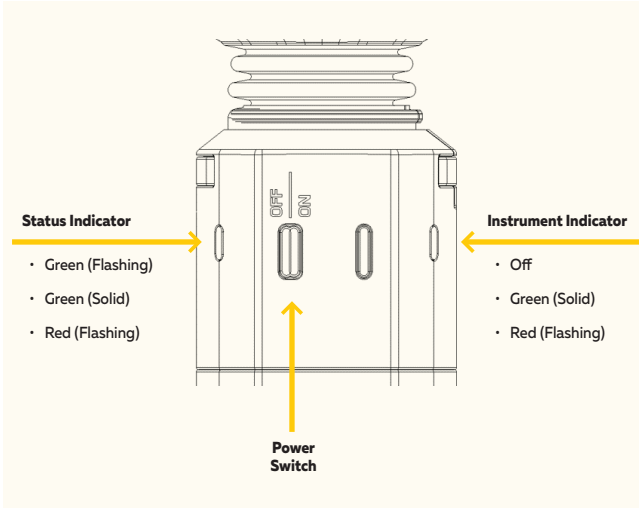

STATUS INDICATOR	INSTRUMENT INDICATOR	
Power switch OFF		
Handheld device powered, instrument registered		
Power switch ON		No instrument Registered
		Standby Mode
		Operating Mode
		System Failure
		Loose Tip

## TROUBLESHOOTING



STATUS	LED's		POSSIBLE EXPLANATION	REMEDY
	Status Indicator	instrument indicator		
Device is not powered ON.			if power is switch OFF:	Turn power switch on.
			if power switch is ON:	Check connection of DC Power Cable and Power Adapter as well as wall source.
Device is powered, but instrument either does not respond to CI movements or does not respond properly.			If the instrument indicator is OFF.	
			If the power and instrument indicators are "flashing" GREEN:	Double click the DIALOG button to activate Operating Mode.
			If power and instrument indicators are "solid" GREEN:	First check if CI movement is being hindered by sterile drape. If there is no mechanical blocking, re-assemble the system with a new instrument.
			If the instrument indicator is "flashing" RED:	First double click the DIALOG button. If LEDs still "flashing" RED, the instrument has failed. Re-assemble the system with a new instrument.
The instrument only articulates left-right.	N/A		Is the free/planar switch set to planar? If YES:	Set to free mode.
The instrument roll range is limited.	N/A		Check The roll range switch.	Set the roll range switch to the desired range.

STATUS	LED's	POSSIBLE EXPLANATION	REMEDY
The instrument cannot be removed from the trocar.	N/A	If the instrument Indicator is solid green and the instrument does not respond to the straight instrument function (3 sec on the DIALOG button).	Use The loose tip function (3 sec) on the stop button as explained in the Prompt Release Section Loose Tip Function (25.a).
	N/A	If the Loose Tip Function does not loosen the instrument tip.	Use the Release Key to manually straighten the instrument as explained above in the manual release section (27. b.).

## POTENTIAL ADVERSE EVENTS



Unknown.

## HANDX CLEANING AND DISINFECTING



- ⚠ **CAUTION:** Do not use hospital sterilization equipment to sterilize or disinfect the HandX Handpiece.
- ⚠ **WARNING:** HandX instruments- Fenestrated Grasper and Needle Holder are intended for single use only, do not attempt to reuse or re-sterilize.
- ⚠ **WARNING:** The HandX Handpiece must be properly reprocessed by cleaning and disinfecting before its first use and after each subsequent use according to the protocol in this section. Using a HandX Handpiece that has not been properly reprocessed presents an acute infection-control risk to both the patient and medical personnel performing or assisting in the procedure.
- ⚠ **CAUTION:** Clean the HandX Handpiece immediately after use in a procedure. Although covered by sterile drape failure to do so may cause debris to harden on the HandX Handpiece handle's external surfaces, which can become difficult to remove.

The HandX Handpiece reprocessing procedure is made up of a series of discrete steps, each of which is essential to successful reprocessing. Closely adhere to the reprocessing instructions given in this chapter.

The cleaning and disinfection process has been validated for cleaning and disinfecting the multi-use HandX Handpiece. It is the responsibility of the user/medical facility to ensure that reprocessing is performed using the appropriate equipment and materials.

## CLEANNING AND DISINFECTION INSTRUCTIONS

1. Remove the sterile drape and disassemble the instrument from the Handpiece before cleaning as detailed in the "Using"-Device Disassembly" section.  
 **CAUTION:** Handpiece should NOT be submerged in water or cleaning solutions
2. Use lint free cloth dampened with filtered water (RO water) to clean the Handpiece surfaces
3. Ensure areas containing crevices are scrubbed thoroughly.
4. Perform visual inspection to verify debris is removed.
5. Use lint free cloth dampened with 70% ethanol to disinfect the whole Handpiece surface. The cleaning procedure will continue at least 30 second.
6. Ensure areas containing crevices are scrubbed thoroughly.
7. Repeat step 5&6.
8. Final wipe - Use lint free cloth dampened with 70% ethanol to disinfect the whole Handpiece surface.
9. **NOTE:** disinfection 70% ethanol wipes may be used as well.

## SERVICE AND MAINTENANCE













Human Xtensions provides a one-year warranty for the Handpiece from the date of delivery to the end user. Human Xtensions is committed to service the Handpiece and the Power Adapter upon request or when needed.

## SYMBOL DEFINITIONS



Following are the graphical symbols and their descriptions used in the HandX:

	Federal (USA) law restricts the device to sale by or on the order of a physician		Caution. There are specific precautions related to the device, refer to IFU
	Do not use if package is damaged or open		Serial Number
	Follow instructions for use		Class II Equipment
	Defibrillation-Proof Type BF Applied Part		Batch Code
	Manufacturer		Date of manufacture
	Use by date		Single Use Only
	Ethylene Oxide Sterilized		Ingress Protection Marking
	Direct current		Humidity limitation
	Keep dry		Atmospheric pressure limitation
	Temperature limit		WEEE - separate collection for EEE
	Quantity		

## TRANSPORT CONDITIONS

HandX instruments & HandX Disposables:

- Temperature: -10°C to 50°C
- Humidity: 10% - 85%

HandX Handpiece:

- Temperature: -10°C to 50°C
- Humidity: 10%-85%
- Pressure: 60 - 102 kPa

## STORAGE CONDITIONS

HandX instruments & HandX Disposables:

- Temperature: 15°C to 30°C
- Humidity: 10% - 85%

HandX handpiece:

- Temperature: -10°C to 50°C
- Humidity: 10% - 85%

## OPERATION ENVIRONMENT CONDITIONS

- temperature: 10°C-35°C
- Humidity: 30% - 75%
- Adapter input: 100V-240V (AC), 0.6A, 50 kHz-60 kHz
- Adapter output: 0.9V, 2.2A
- Rated input: 9V (DC), 1.5A
- Pressure: 80 - 102 kPa



## ELECTROMAGNETIC COMPATIBILITY (EMC) DECLARATIONS

The HandX System was tested according to EMC requirements of IEC-60601-1-2 4<sup>th</sup> edition.

### GUIDANCE AND MANUFACTURER'S DECLARATION –ELECTROMAGNETIC EMISSIONS

The HandX is intended for use in the electromagnetic environment specified below. The customer or the user of the HandX should assure that it is used in such an environment.

EMISSIONS TEST	COMPLIANCE	ELECTROMAGNETIC ENVIRONMENT – GUIDANCE
RF emissions CISPR 11	Group 1	The system uses Radio Frequency (RF) energy only for its internal function. Therefore, its RF emissions are very low and are not likely to cause any interference in nearby electronic equipment.
RF emissions CISPR 11	Class B	The HandX is suitable for use in all establishments, including domestic establishments and those directly connected to the public low-voltage power supply network that supplies buildings used for domestic purposes.
Harmonic emissions IEC 61000-3-2	Class A	
Voltage Fluctuations/ flicker emissions IEC 61000-3-3	Complies	

### GUIDANCE AND MANUFACTURER'S DECLARATION – ELECTROMAGNETIC IMMUNITY

HandX is intended for use in the electromagnetic environment specified below. The customer or the user of the HandX should assure that it is used in such an environment.

IMMUNITY TEST	IEC 60601-1-2 TEST LEVEL	COMPLIANCE LEVEL	ELECTROMAGNETIC ENVIRONMENT – GUIDANCE
Electrostatic discharge (ESD) IEC 61000-4-2	±8 kV contact ±2 kV, ±4 kV, ±8 kV, ±15 kV air	±8 kV contact ±15 kV air	Floors should be wood, concrete or ceramic tile. If floors are covered with synthetic material, the relative humidity should be at least 30%.
Electrical fast transient/ burst IEC 61000-4-4	±2 kV for power supply lines ±1 kV for input/output lines	±2 kV for power supply lines N/A	Mains power quality should be that of a typical commercial or hospital environment.
Surge IEC 61000-4-5	± 1 kV differential mode ± 2 kV common mode	± 1 kV differential mode ± 2 kV common mode	Mains power quality should be that of a typical commercial or hospital environment.

IMMUNITY TEST	IEC 60601-1-2 TEST LEVEL	COMPLIANCE LEVEL	ELECTROMAGNETIC ENVIRONMENT - GUIDANCE
Voltage dips, short interruptions and voltage variations on power supply input lines IEC 61000-4-11	UT = 0%, 0.5 Cycle  UT = 0%, 1 Cycle  UT = 70%, 25/30 cycles  UT = 0%, 250/300 cycles	At 100 VAC and 230 VAC:  0% UT for 10 ms  0% UT for 20 ms  70% UT for 500 ms  0% UT for 5 seconds	Mains power quality should be that of a typical commercial or hospital environment. If the user of the System requires continued operation during power mains interruptions, it is recommended that System be powered from an uninterruptible power supply or a battery.
Power frequency (50/60 Hz) magnetic field IEC 61000-4-8	30 A/m	30 A/m	Power frequency magnetic fields should be at levels characteristic of a typical location in a typical commercial or hospital environment.
Conducted RF IEC 61000-4-6	3 Vrms 150 kHz to 80 MHz 6 Vrms in ISM bands	3 & 6 Vrms on 0.15 ÷ 80 MHz, 80% AM at 1kHz	Field strengths from fixed RF transmitters, as determined by an electromagnetic site survey <sup>a</sup> , should be less than the compliance level in each frequency range <sup>b</sup> .
Radiated RF Immunity IEC 61000-4-3	3.0 V/m 80 MHz ÷ 2.7 GHz, 80% AM, 1 KHz	3.0 & 10.0 V/m 80 MHz ÷ 2.7 GHz, 80% AM, 1 KHz	Interference may occur in the vicinity of equipment marked with the following symbol:  
RF wireless communications equipment fields Immunity	Frequencies and levels as specified at IEC 60601-1-2 table 9	Frequencies and levels as specified at IEC 60601-1-2 table 9  Max -28V/m	

**NOTE 1:** At 80 MHz and 800 MHz, the higher frequency range applies.

**NOTE 2:** These guidelines may not apply in all situations. Electromagnetic propagation is affected by absorption and reflection from structures, objects and people.

---

- <sup>a</sup> Field strengths from fixed transmitters, such as base stations for radio (cellular/cordless) telephones and land mobile radios, amateur radio, AM and FM radio broadcast and TV broadcast cannot be predicted theoretically with accuracy. To assess the electromagnetic environment due to fixed RF transmitters, an electromagnetic site survey should be considered. If the measured field strength in the location in which the System is used exceeds the applicable RF compliance level above, the System should be observed to verify normal operation. If abnormal performance is observed, additional measures may be necessary, such as re-orienting or relocating the system.
- <sup>b</sup> Over the frequency range 150 kHz to 80 MHz, field strengths should be less than [V1] V/m.

**HUMAN  
XTENSIONS™**

[human-x.com](http://human-x.com)

---